

Features

- 5630 IR VCSEL
- ROHS and REACH Compliant
- ESD(HBM) 8KV

Applications

- Industrial facility applications
- Consumer Mobile
- Automotive Interior & Exterior
- 3D Sensing(TOF, Structure Light)
- Bio recognition



Description

The INV-P53CTRHIR is a low-power IR VCSEL. It is a SMD type package which can be used in various applications.

Recommended Solder Pattern

(Suggest Stencil $t=0.12$ mm)

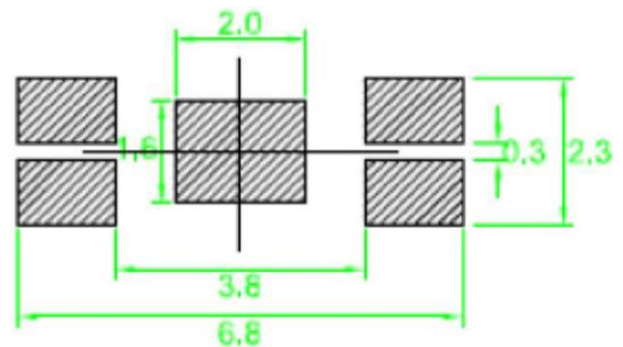

Figure1. INV-P53CTRHIR Solder Pattern

Package Dimensions in mm

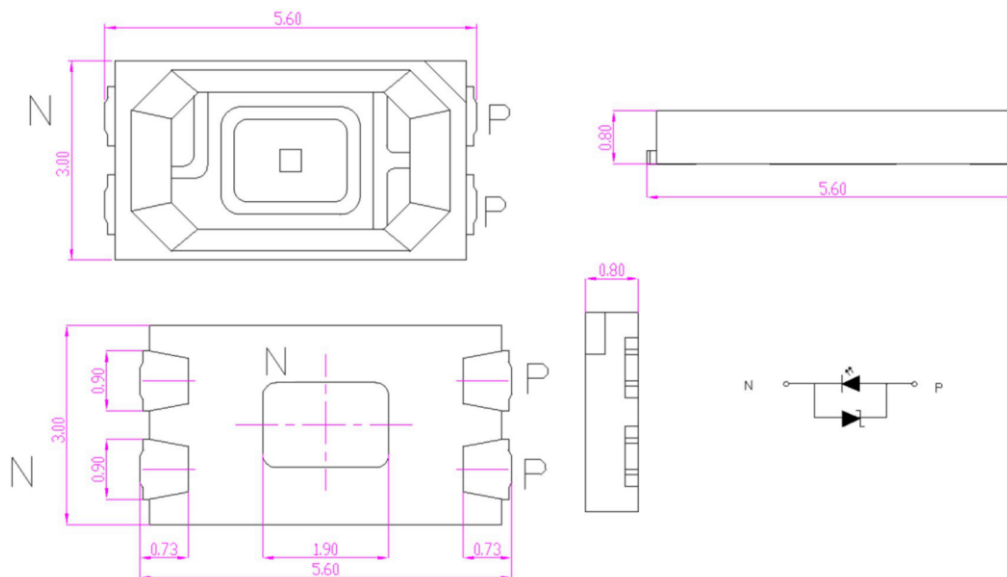

Figure 2. INV-P53CTRHIR Package Dimensions

*Note

All dimensions are in millimeters.
Tolerance is ± 0.1 mm unless other specified.

Absolute Maximum Rating at 25°C (Note 1)

Product	I _{FP} (mA) max	P _d (W) max	V _R (V) Typ.	T _j (°C) Typ.	T _{ST} (°C)	R _{th} (°C/W)	Soldering Temp. T _{sol} (°C)	ESD HBM (V)
INV-P53CTRHIR	240	0.56	-5	110 °C	-40°C~+120°C	60	260 °C	8000

Notes

1. For other ambient, limited setting of current will depend on de-rating curves.
2. D=0.01s duty 1/10.
3. When drive on maximum current , T_j must be kept below 110°C
4. Viewing angle(2θ 1/2) ± 10°

Electrical Characteristics T_A = 25°C (Note 1)

Product	V _F (V)@200mA		Radiometric Power (mW) @200mA		Peak Wavelength (nm)		I _R (μA)	View Angle
	min	max	min	max	min	max	max	2θ 1/2
INV-P53CTRHIR	1.8	3.0	90	150	930	950	3	30

***Notes**

1. Performance guaranteed only under conditions listed in above tables.
2. Viewing angle(2θ1/2) ± 10°

ESD Precaution

ATTENTION: Electrostatic Discharge (ESD) protection



The symbol above denotes that ESD precaution is needed. ESD protection for GaP and AlGaAs based chips is necessary even though they are relatively safe in the presence of low static-electric discharge. Parts built with AlInGaP, GaN, or/and InGaN based chips are STATIC SENSITIVE devices. ESD precaution must be taken during design and assembly.
If manual work or processing is needed, please ensure the device is adequately protected from ESD during the process.

Please be advised that normal static precautions should be taken in the handling and assembly of this device to prevent damage or degradation which may be induced by electrostatic discharge (ESD).

Binning Definition (Binning@200mA)**Power Bin**

Bin Code	Min.	Max.	Unit
W94	90	150	mW

Wavelength Bin

Bin Code	Min.	Max.	Unit
W94	930	950	nm

Voltage Bin

Bin Code	Min.	Max.	Unit
V1	1.8	2.2	V
V2	2.2	2.6	
V3	2.6	3.0	

***Notes:**

1. Radiometric Power (P_o) $\pm 10\%$.
2. Wavelength (W_p) $\pm 2.0\text{nm}$
3. Forward voltage (V_f) $\pm 0.12\text{V}$

Electronic-Optical Characteristics

Spectrum Distribution

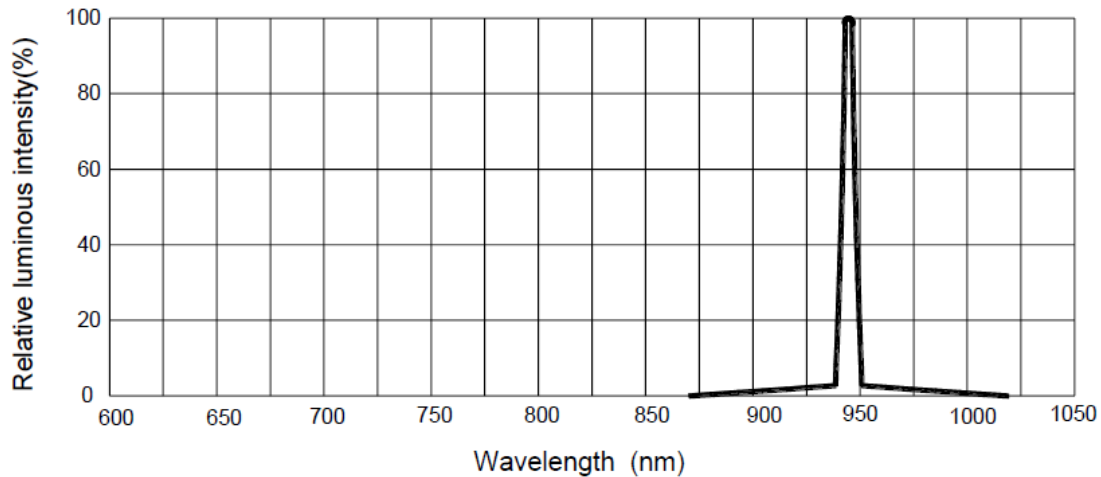

Forward Current VS. Forward Voltage

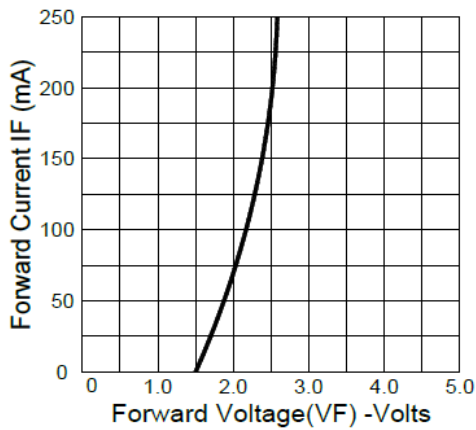

Luminous Intensity VS. Forward Current

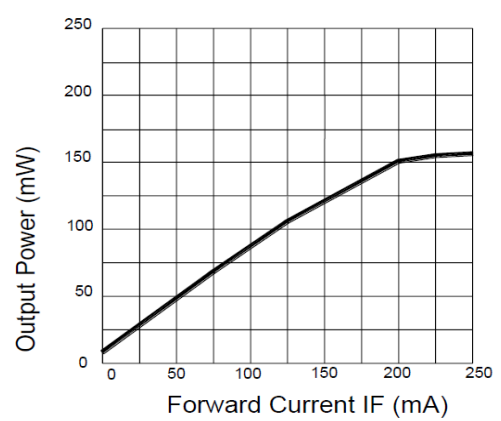
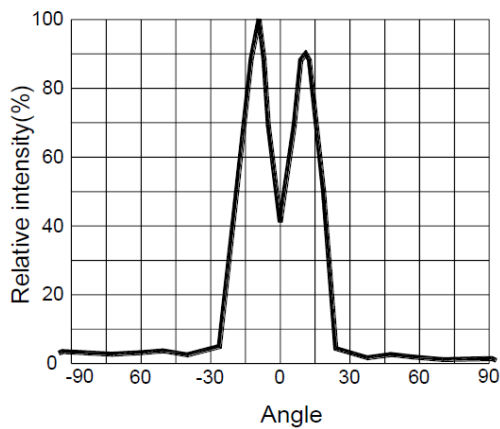
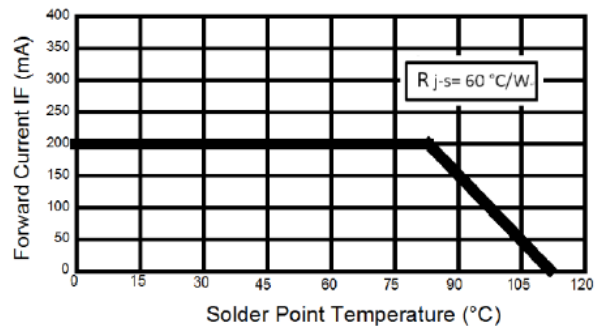

Beam angle (2θ1/2) 30D

Thermal Design for De-rating

***Notes:**

Viewing angle (2θ1/2) ± 10°

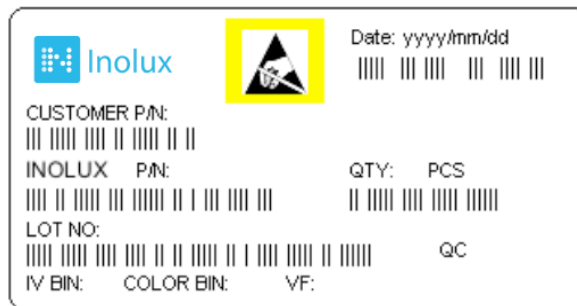
Ordering Information

Orderable Part Number	Peak Wavelength (nm)	Radiometric Power (mW) @200mA		Forward Voltage (V) @200mA		Viewing Angle
		Min	Max	Min	Max	
INV-P53CTHIR	930-950	90	150	1.8	3.0	30°

Label Specifications



Inolux P/N:

INV	-	P	5	3	C	T	R		HIR	-	X	X	X	X
		Material	Package		Variation	Orientation	Current	Lens	Color		Customized Stamp-off			
Inolux VCSEL		P = PLCC Type	53C = 5.6 x 3.0, 120 Deg.			T = Top Mount	R = 200mA	(Blank) = Clear	HIR = 940nm					

Lot No.:

Z	2	0	1	7	01	24	001
Internal Tracker	Year (2017, 2018,)				Month	Date	Serial

Reflow Soldering

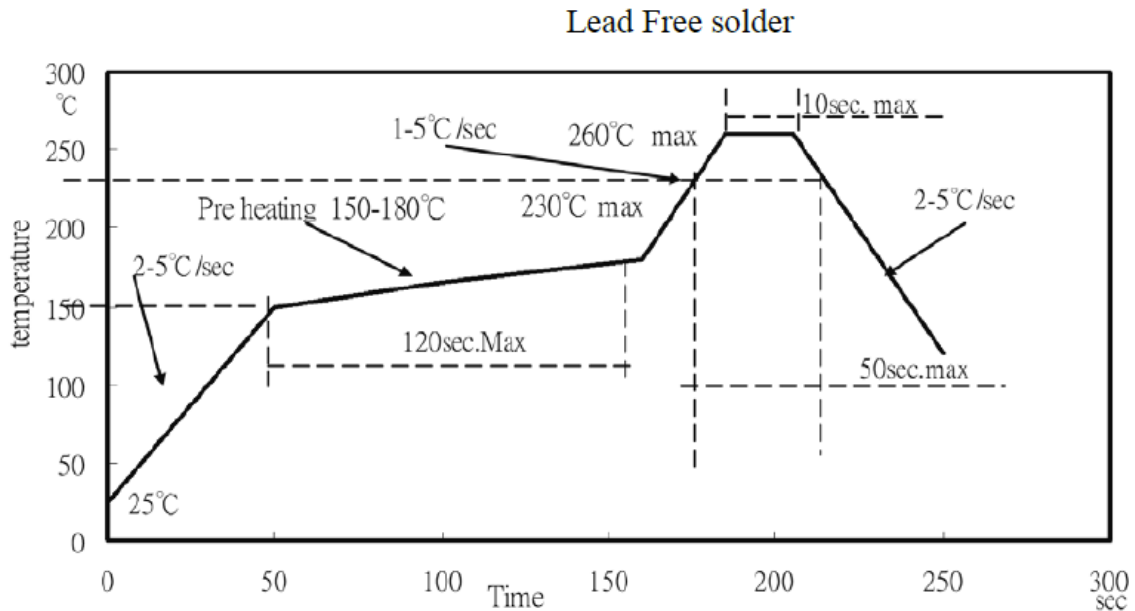

Soldering Iron

Basic Spec is ≤ 4 sec. when 260°C (+10°C \rightarrow -1 second). Power dissipation of Iron should be less than 15W. Surface temperature should be under 230°C

Rework

Rework should be completed within 4 second under 245°C

Notes

1. Do not stress the silicone resin while it is exposed to high temperature.
2. The number of reflow process should not exceed 3 times.

Packing

Carrier Tape Dimensions: Loaded quantity 3000pcs per reel.

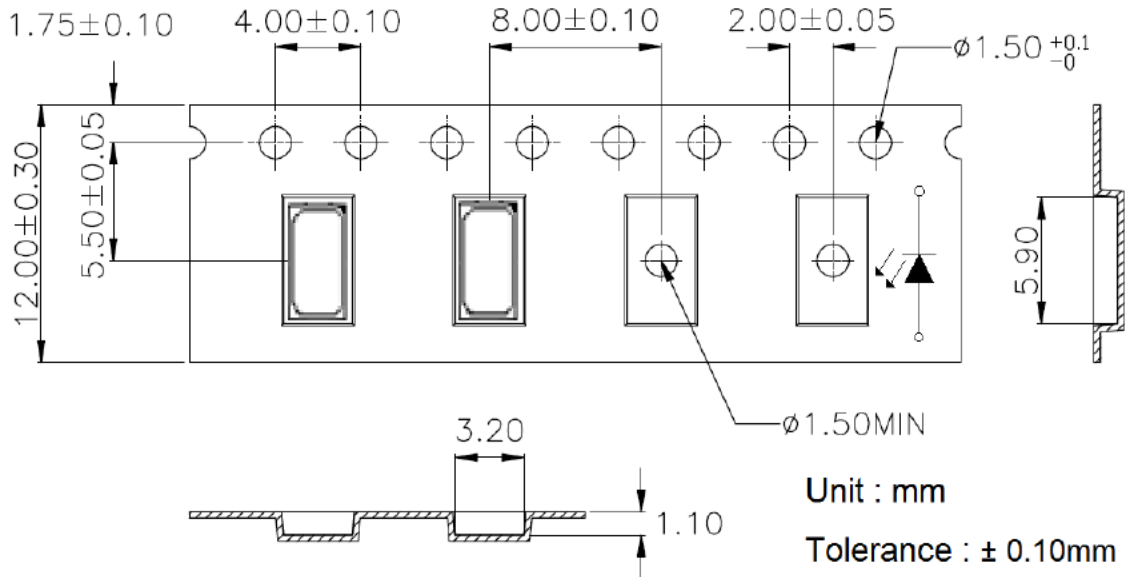

Reel Dimensions:

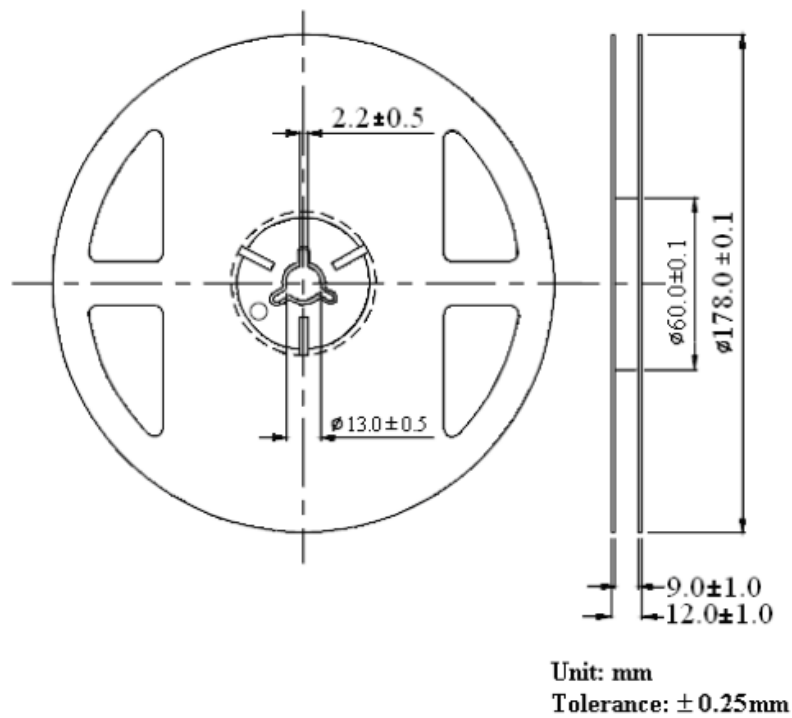

Test Items and Results of Reliability

Test Item	Test Conditions	Duration/ Cycle	Number of Damage	Reference
Thermal Shock	-40°C 30min ↑↓5min 125°C 30min	100 cycles	0/22	AECQ101
High Temperature Storage	Ta=100°C	1000 hrs	0/22	EIAJ ED-4701 200 201
Humidity Heat Storage	Ta=85°C RH=85%	1000 hrs	0/22	EIAJ ED-4701 100 103
Low Temperature Storage	Ta=-40°C	1000 hrs	0/22	EIAJ ED-4701 200 202
Life Test	Ta=25°C If=200mA	1000 hrs	0/22	Tested with Inolux standard
High Humidity Heat Life Test	85°C RH=85% If=200mA	1000 hrs	0/22	Tested with Inolux standard
High Temperature Life Test	Ta=85°C	1000 hrs	0/22	Tested with Inolux standard
ESD(HBM)	2KV at 1.5kΩ;100pf	3 Times	0/22	MIL-STD-883

Criteria for Judging the Damage				
Item	Symbol	Condition	Criteria for Judgment	
			Min	Max
Forward Voltage	VF	If=200mA	-	USL ¹ ×1.1
Reverse Current	IR	VR =5V	-	100μA
Luminous Intensity	Iv	If=200mA	LSL ² ×0.7	-

Notes:

1. USL: Upper specification level
2. LSL: Lower specification level

Revision History

Changes since last revision	Page	Version No.	Revision Date
Initial Release		1.0	02-03-2019
Update the Drawing and Parameter	1,2,3,4	1.1	05-13-2019
Update the Drawing	1	1.2	03-05-2021

DISCLAIMER

INOLUX reserves the right to make changes without further notice to any products herein to improve reliability, function or design. INOLUX does not assume any liability arising out of the application or use of any product or circuit described herein; neither does it convey any license under its patent rights, nor the rights of others.

LIFE SUPPORT POLICY

INOLUX's products are not authorized for use as critical components in life support devices or systems without the express written approval of the President of INOLUX or INOLUX CORPORATION. As used herein:

1. Life support devices or systems are devices or systems which, (a) are intended for surgical implant into the body, or (b) support or sustain life, and (c) whose failure to perform when properly used in accordance with instructions for use provided in the labeling, can be reasonably expected to result in a significant injury of the user.
2. A critical component in any component of a life support device or system whose failure to perform can be reasonably expected to cause the failure of the life support device or system, or to affect its safety or effectiveness.